

Murata MXHQ87WA3000 PDF

深圳创唯电子有限公司

<http://www.murata-ec.com>

■ Notice (Operating)

1. Environment Conditions

- (1) This product is designed for use in electrical equipment in the environment (temperature, humidity, atmospheric pressure, etc.) specified in this approval drawing. It may not be used in the following environments or under the following conditions:
- (a) Ambient air containing corrosive gas (Chlorine gas, Hydrogen sulfide gas, Ammonia gas, Sulfuric acid gas, Nitric oxide gas, etc.)
 - (b) Ambient air containing volatile or combustible gas
 - (c) In liquid (water, oil, chemical solution, organic solvents, etc.)
 - (d) In environments with a high concentration of airborne particles
 - (e) In direct sunlight

- (f) Dusty conditions
 - (g) In freezing
 - (h) Other environments similar to the above conditions
- (2) Contact the manufacturer before using the product in any of the above environments or under any of the above conditions.

2. Storage

Store in manufacturer's package or tightly re-closed box with the following conditions. Use this product within 6 months after receipt. Check the terminal solderability before use if the product has been stored for more than 6 months.

Temperature: -10 to +40°C

Humidity: 15 to 85% RH

■ Notice (Handling)

1. Automatic Measurement Probe (MM126310)

- Automatic measurement probe (MM126310) should be used on the condition in Fig. 1 for good connection without any damages.
- The pressure force is 5N to 9N with vertical ($0 \pm 2^\circ$).

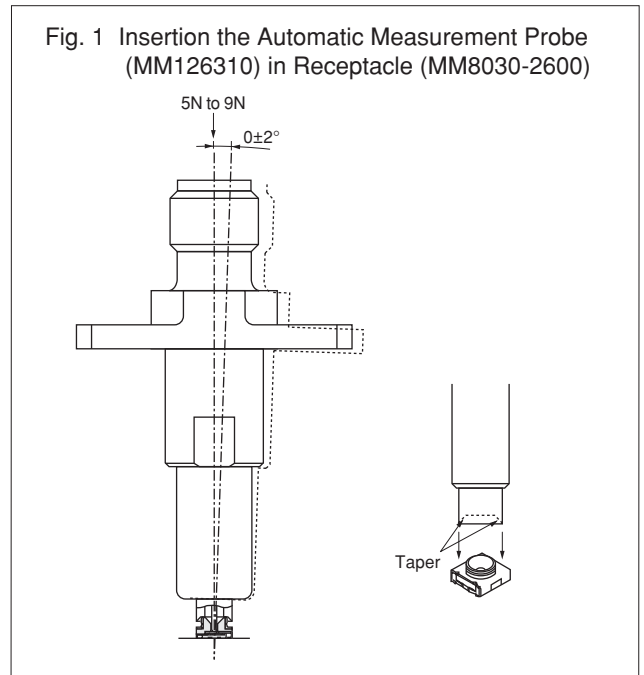

2. L Type Probe with Locking Function (MXHQ87WA3000)

- Do not try to pull the cable, when a connector with a coaxial cable is handled.
- Do not give a twisted torque to the cable and connector.
- Mechanical stress:
 - The stress to the connector should be limited as figure shown right.
 - (1) Stress to the housing.
 - Stress A and B: 0.4N max.
 - (2) Stress to the outer sleeve.
 - Stress C: 0.3N max.
 - Stress D: 0.3N max.
 - (3) Cable pull strength.
 - Stress E: 0.4N max.

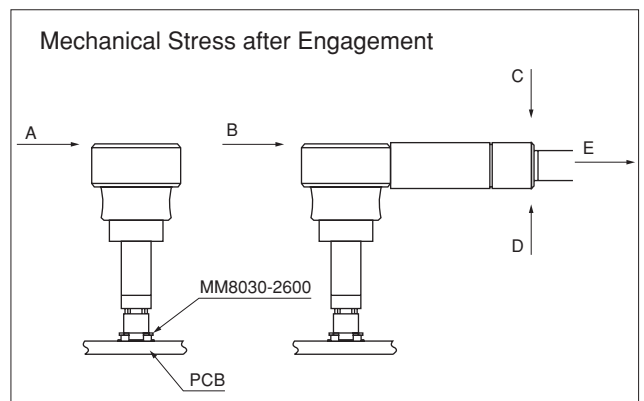

Continued on the following page.

Caution · Notice

 Continued from the preceding page.

3. Usage Condition

- (1) Do not apply electrical voltage greater than specified in the catalog. It might cause degradation or destruction of the product. Even if it endures during a short time, long time qualification is not guaranteed.
- (2) Confirm that product performance is not influenced with any other components or materials which directly contact products.

4. Handling

Do not apply excessive shock or load to subassembly products such as soldered printed circuit board in case handling or transporting.